

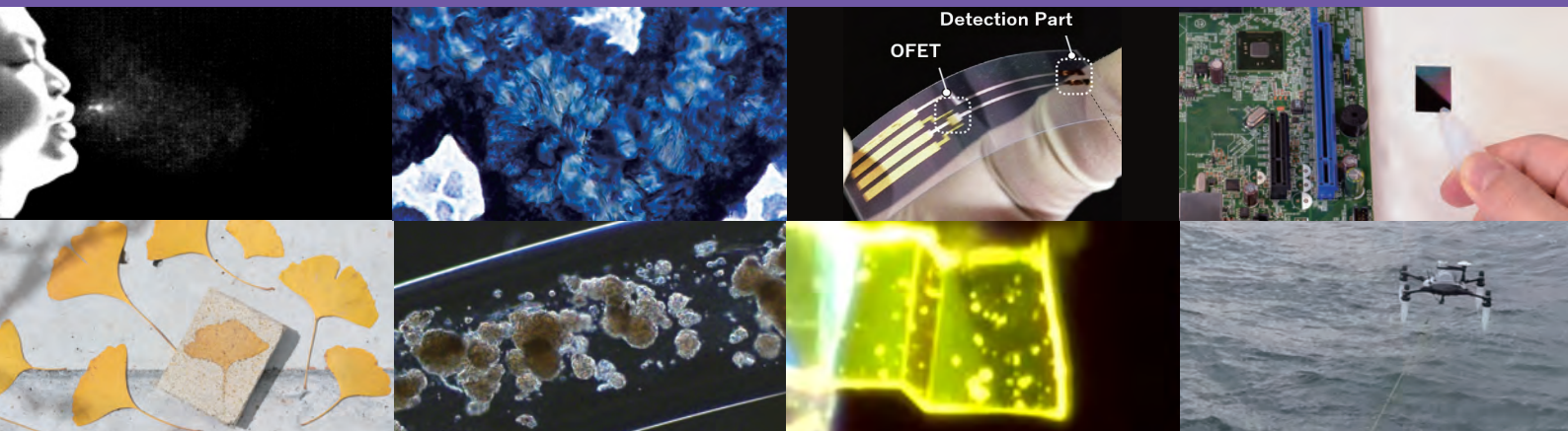

# UTokyo-IIS Bulletin

Vol.6 September 2020

Institute of Industrial Science,  
The University of Tokyo



東京大学生産技術研究所

Institute of Industrial Science, The University of Tokyo

# Visualizing COVID-19:

## Insights into the dynamics of airborne as a potential transmission pathway



Professor Ryozo Ooka

**G**lobal efforts to combat COVID-19 are proving to be extremely challenging. Epidemiologists, medical care experts, and public health policy makers are struggling to mitigate the spread of this disease that has infected approximately 20 million globally as of 11 August 2020, according to statistics compiled by John Hopkins University.

To-date a combination of washing hands and social distancing have been the two main pillars of public health measures to prevent the spread of the disease. Recently, however, an

increasing number of scientists are concerned about the possibility of the SARS-CoV-2 coronavirus could be transmitted through the air in the form of micrometer sized droplets known as aerosols.

“I have recently launched a project to study the potential air borne spread of COVID-19,” says Ryozo Ooka, a professor of the Institute of Industrial Science, The University of Tokyo (UTokyo-IIS). “The project is funded by UTokyo-IIS as part of the Institutes contribution to develop measures for mitigating the spread of COVID-19.”

### Visualizing aerosols and droplets originating from humans

**T**he two fundamental questions being addressed Ooka and his colleagues at the UTokyo-IIS are what types of droplets are released during breathing, conversation, and coughing, and how far they travel through the air. So accurate analysis to resolve these issues necessitates the development

of technology for visualizing the droplets emanating from a person's mouth.

In preliminary experiments Ooka's team constructed a visualization system consisting of strong white light sources and a high-speed camera (1000 frames per second) set up in a

photography studio of UTokyo-IIS. The subject is illuminated by strong light from one side of their face and the camera is positioned on the opposite side to capture droplets emanating from the mouth during scenarios mimicking real-life including coughing, sneezing, and casual conversation.

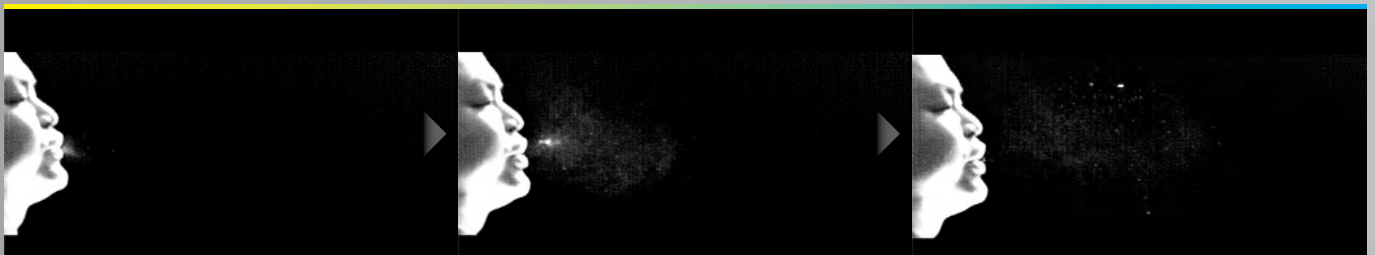



# microdroplets exhaled by humans of the new coronavirus

## Early findings and sustainable cities of the future

“Our experiments have shown that 20 micrometer sized droplets exhaled during simulated sneezing travel about 110 cm before falling to the ground,” explains Ooka. “They are heavy, so they do not travel far. Notably, we observed greater exhalation of droplets

after consuming fizzy drinks, such as carbonated fruit juice. We plan to use laser scattering for more in-depth analysis of the size distribution and range of microdroplets emitted. Also, we are conducting computer simulations to clarify the variation of droplet size with the time that they stay airborne.” The computer simulations enable the researchers to

design rooms with a wide range of parameters such as range of size of droplets, location for ventilation ducts, and the source of droplets, for example, whilst talking or sneezing.

The significance of this research is wide ranging.

Ooka and his colleagues hope that their insights into the dynamics of these microdroplets will be used for formulating government policy and public healthcare guidelines for ventilating offices and houses to stop the spread of COVID-19. Furthermore, this research could be expanded into analyzing aerosols in the context of large gatherings such as cinema’s and choral settings for indoor musical events.

“I have spent my professional life working on designing and analyzing buildings for building sustainable cities,” says Ooka. “The COVID-19 crisis has energized and focused my thoughts to use my experience to design adaptive cities of the future that are robust enough to protect inhabitants from the spread of disease. A really challenging and worthwhile area of research.”



### Further information

Ooka Laboratory  
<http://venus.iis.u-tokyo.ac.jp/en/>

# Turning adversity into

## UTokyo-IIS researcher studies how to

In mid-March 2020, when Kaori Sugihara moved to Japan from Switzerland to join UTokyo-IIS as a researcher, COVID-19 was raging in Europe and creeping into Japan, affecting airline services. Had her departure been even a day later, she might have missed a connecting flight and got stranded before arriving in Tokyo, she says.

Then, after starting in her position as a lecturer of biophysical engineering at the UTokyo-IIS in April, Sugihara found her hands were tied. A range of sophisticated equipment she had arranged to ship from her former lab at the University of Geneva didn't arrive as scheduled, as the pandemic disrupted cargo transport.

But Sugihara says this pause in research gave her time to reflect on her projects and find a new focus. It also provided her the opportunity to come up with a new idea to apply her expertise to recycling N95 masks, whose shortage is a serious problem for front-line health care workers worldwide.

"With no equipment and no one else in the lab, I felt my research career was in crisis. But I wondered if there was anything I could do on my own, with just the small instruments available and using my own hands, like back when I was a student working in a lab," she said. "That's how my little project on masks started."

An N95 mask protects the wearer against airborne particles, including those containing viruses, with an electrically charged filter. The number 95 denotes the minimum percentage of airborne particles that the mask can capture. (Surgical masks wouldn't offer the same protection, Sugihara says, as they don't fit as snugly to faces as N95 masks.) This filter not only physically blocks particles, but also uses static

electricity to capture the ones that would otherwise sneak through. But what is less known is that the mask's static electricity is lost over time, especially when the mask is exposed to moisture or disinfectant spray. If the mask is cleaned in a washer, the static electricity could almost completely disappear, causing the face covering to lose its filtering efficiency.

When Sugihara learned through TV news coverage about the shortage of N95 masks and how they were being washed and reused at hospitals, she was alarmed. This is why she started studying whether applying voltage directly to the sterilized masks could restore their static electricity.

Sugihara is currently making a prototype of a hand-held machine where a used and disinfected N95 mask can be sandwiched between two electrically charged metal plates, much like a waffle maker.



A reading on a static meter shows that an N95 mask has a negative voltage of minus 1,094 volts.

She is also studying how the weather and humidity affect the strength of static electricity in N95 masks.



Lecturer Kaori Sugihara



# opportunity

## recycle N95 masks

**C**uriosity has always driven Sugihara, who was born in Nagoya and raised in Tokyo. She majored in physics at Keio University in Tokyo before enrolling in a master's program at UTokyo-IIS, pursuing semiconductor physics. But she gradually became interested in working in a field where she can apply her findings to help cure diseases or make people healthy. That's why she switched to biophysical engineering, as it allowed her to combine her physics background and interest in biomedical research.

Sugihara was also interested in studying abroad. While she had no leads or contacts; she "Googled" professors heading biophysical engineering labs at European institutions and contacted them by email, interviewing for and successfully enrolling in a doctoral program at ETH Zurich (Swiss Federal Institute of Technology in Zurich, Switzerland). There, she was tasked with a project on ion channels, proteins controlling the flow of ions in and out of cells. "Ion channels, which are located in cell membranes, are like mouths for cells," Sugihara explained. "When they are opened, they let ions pass through the cells, and when they are closed, they block the ions' passage."

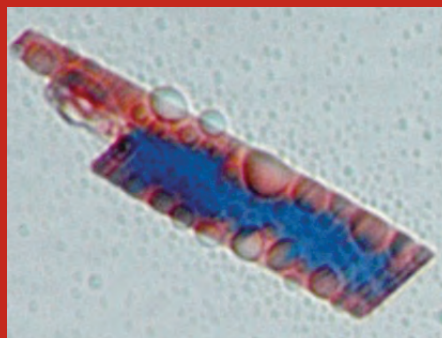

A microscopic image of materials known as mechanochromic polymers shows that the color of the polymers changes from blue to red where peptides (chains of amino acids) are added. This occurs because the peptides apply force to the polymers by pulling or pushing them. (Originally published in *Macromolecules* 53 (15), 6469-6475 (2020). DOI: 10.1021/acs.macromol.0c00718)

Ion channels are particularly important in the brain, where the passage or blockage of ions dictates consciousness, sleep and the visual senses.

Scientists study the flow of ions by applying voltage on both sides of cell membranes and measuring the current. When an electric current is registered, it means that an ion channel has opened and has let ions through.

Sugihara's research — jointly conducted with a Swiss pharmaceutical company — was aimed at improving the efficiency of a machine called the automated patch clamp. Such machines screen millions of chemicals that might switch ion channels on or off. The drugmaker developed the device so it can quickly find chemicals that might work for psychiatric conditions such as sleep disorders and depression. But the machine needed improvement as it wasn't as good as humans at manipulating nanoscale ion channels, she said.

After obtaining her doctor of science degree at ETH Zurich, Sugihara continued research at the intersection of physics, engineering and biology. After a two-year stint as a postdoctoral researcher at the Max Planck Institute for Intelligent Systems in Stuttgart, Germany, she landed a tenure-track assistant professor position at the University of Geneva in 2014, a position she held until her return to Japan this spring.

One of her current research fields is mechanobiology, which studies how physical forces such as tension and osmotic pressure affect cells, tissues and organs. Sugihara says she is particularly interested in technology that helps scientists measure such forces on a nanoscale level. By incorporating a mechanochromic polymer, something that emits

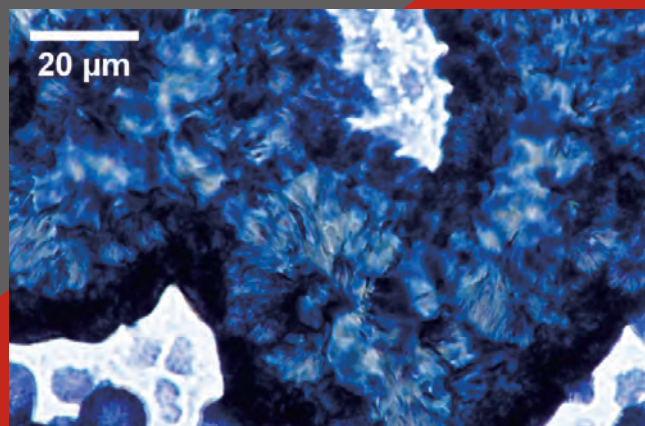

A microscopic image of materials known as mechanochromic polymers

fluorescence when it is pushed, into cell membranes, she is hoping to visualize how molecules in living organisms are pushing and pulling cell membranes.

"For example, cancer cells are known to be harder than healthy cells," she said. "Researchers have long sorted cancerous cells from noncancerous ones by looking for proteins found only in the former. But using a special microscope called an atomic force microscope, some researchers are now working to push cells on a nanoscale level, measure the stiffness of the cells and thus determine whether they are cancerous or not."

Sugihara, who calls herself a "tool developer," says she wants to create tools that biomedical researchers can use.

"I consider it my job to work with end users — such as biologists, pharmaceutical companies and medical doctors — and to use physics and engineering to come up with applications that meet their needs," she said. "I would like to create what they really need. That's my ultimate goal."

For now, though, she is busy with masks. She also says COVID-19 has given her a chance to think deeply on what she can do during the pandemic.

"Biological experiments often take up to a year to prepare. So I know how hard it is for scientists doing experiments to see their plans get derailed by the pandemic, because they would have to start all over again," she said.

"For my part, I've been trying to produce something out of nothing. And instead of simply continuing what I have researched, I'm taking a hard look again at my research and thinking of new ways to make it grow."

Interview / Text : Tomoko Otake

### Further information

Sugihara Laboratory  
<https://sugiharalab.iis.u-tokyo.ac.jp/>

# FOCUS on organic field effect transistor biosensors to combat COVID-19

Innovative organic transistor-based biosensors show potential as compact, inexpensive, and sensitive portable devices for medical diagnostics in the fight to contain the new corona virus.

## Birth of extended-gate OFET biosensor

**W**e first demonstrated the potential applications of organic field effect transistors (OFET) for reliable immunosensing in 2014 in a paper published in *Applied Physics Letters* [1],” says Tsuyoshi Minami, an associate professor specializing in applied supramolecular chemistry at UTokyo-IIS. “We fabricated so-called ‘extended-gate’ OFETs to mitigate

degradation of OFET devices when immersed in aqueous solutions. It was a major innovation and our paper was one the most accessed publications in the *Biophysics and Bio-Inspired Systems* in *APL* for 2014 to 2016 [2].”

Specifically, the extended gate sensing region consists of a gold film evaporated onto a flexible

plastic (polyethylene naphthalate (PEN)) enabling its surface to be biologically functionalized. Notably, this ‘flexible biochemical sensor’ is separated from the main transistor part of the whole structure, which is not exposed to liquids during measurements.

## Extended gate OFET biosensors evolve

**T**he early extended gate OFET devices were successfully used to detect biotinylated immunoglobulin G (IgG). “The important features of our biosensing approach is that they operate at low voltages of less than 3V and are small and inexpensive compared with conventional enzyme-linked immunosorbent assay (ELISA) protocols,” explains Minami. “Also the devices can be fabricated using printing technology. There are many opportunities to innovate and expand this research, for example, into the realm of flexible and wearable electronics and wireless communications.”

His group also functionalized their OFET with enzymes to detect biologically benign ions. For example, a nitrate reductase on their OFET allows us to detect nitrate ion in human saliva [3]. More recently, Minami and his colleagues reported on the use of their devices to detect

a wide range of chemicals by functionalizing the extended gate sensors with ‘artificial receptors’ [4]. “This series of experiments demonstrated the possibility of combining host-guest chemistry with our devices,” explains Minami. “We functionalized our OFETs with artificial receptors for electrically detecting a wide range of targets

including organic and inorganic ions and proteins.” Specific targets-receptor pairs included copper ions and nitrilotriacetic acid (nta); mercury ions and thiolated dipicolylamine (dpa); histamine and 5-carboxy-1-pentanethiol (CPT); and fluorine contamination in water with a phenylboronic acid (PBA) receptor.

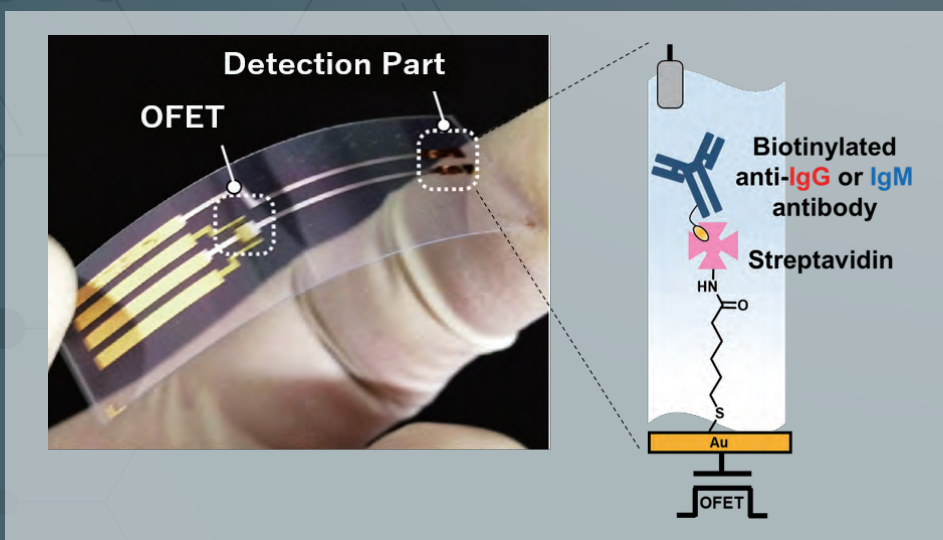





Master Course 2nd Koichiro Asano of Minami Lab., holding an OFET in his right hand

## Detection of proteins to combat COVID-19

**E**LISA is currently widely used for COVID-19 testing. This method consists of a complicated four step process consisting of an antibody, analyte, a secondary antibody with an enzyme. Furthermore, it can take between hours to days for the results to become available.

In contrast the so-called “label-free” technology developed by Minami and colleagues is not only simple, portable, and inexpensive but also fast, with the results known within

minutes. “We functionalize the gold surface of the extended gate electrode sensing area by a self-assembly process,” says Minami. “We immobilize anti-IgG antibody on gate electrode via the streptavidin-biotin conjugation. This enables the detection of IgG.”

Initial experiments are promising with titration results showing a negative shift of the transfer curve of the OFET with increasing the target IgG concentration, and a detection limit of 0.62  $\mu\text{g}/\text{mL}$ , which is approximately 4  $\text{nmol}/\text{L}$ .

“I am confident that our extended gate OFET biosensors will play an important role in containing the spread of COVID-19,” says Minami. “I am collaborating with industrial partners to take this technology from the lab to real-life applications in society.”

### Reference

- [1] Tsukuru Minamiki et al, Accurate and reproducible detection of proteins in water using an extended-gate type organic transistor biosensor, *Appl. Phys. Lett.* **104**, 243703 (2014). DOI: 0.1063/1.4883739
- [2] Most accessed articles in specific sections of Applied Physics Letters 2014 to 2016. <http://aip-info.org/1XPS-3JAU5-E8G1C0LX17/cr.aspx?v=1> <http://aip-info.org/1XPS-4IFU0-E8G1C0LX17/cr.aspx>
- [3] Tsuyoshi Minami et al, Selective nitrate detection by an enzymatic sensor based on an extended-gate type organic field-effect transistor, *Biosens. Bioelectron.* **81**, 15, 87–91, (2016). DOI: 10.1016/j.bios.2016.02.036
- [4] Riku Kubota et al, Chemical Sensing Platforms Based on Organic Thin-Film Transistors Functionalized with Artificial Receptors, *ACS Sens.* **4**, 10, 2571–2587, (2019). DOI: 10.1021/acssensors.9b01114

### Further information

Minami Laboratory  
<http://www.tminami.iis.u-tokyo.ac.jp/en/>



Associate Professor  
Masaharu Kobayashi

Postdoctoral Researcher  
Jixuan Wu

# Memory meets processor: Spiraling Circuits for More Efficient AI

**R**esearchers from UTokyo-IIS designed and built specialized computer hardware consisting of stacks of memory modules with computing function arranged in a 3D-spiral for artificial intelligence (AI) applications. This research may open the way for the next generation of energy efficient AI devices.

Machine learning is a type of AI that allows computers to be trained by example data to make predictions for new instances. For example, a smart speaker algorithm like Alexa can learn to understand your voice commands, so it can understand you even when you ask for something for the first time. However, AI tends to require a great deal of electrical energy to train and predict, which raises concerns toward sustainable society.

Now, scientists from UTokyo-IIS have developed a novel design for stacking resistive random-access memory modules with oxide semiconductor (IGZO)

access transistor in a three-dimensional spiral. Having computing functionality on on-chip nonvolatile memory makes the machine learning training and prediction process much faster and more energy efficient. This is because data transfer between memory and processor is no longer required compared with conventional computer hardware. Stacking multiple layers of circuits is a natural step just like a brain architecture, since training the algorithm and prediction often requires many operations to be run in parallel at the same time.

“For these applications, each layer’s output is typically connected to the next layer’s input. Our architecture greatly reduces the need for interconnecting wiring,” says first author Jixuan Wu.

The team was able to make the device even more energy efficient by implementing a system of binarized neural networks. Instead of allowing the

parameters to be any number, they are restricted to be either +1 or -1. This both greatly simplifies the hardware used, as well as compressing the amount of data that must be stored. They tested the device using a common task in AI, interpreting a database of handwritten digits. The scientists showed that increasing the size of each circuit layer could enhance the accuracy of the algorithm, up to a maximum of around 90%.

“In order to keep energy consumption low as AI becomes increasingly integrated into daily life, we need more specialized hardware to handle these tasks efficiently,” explains Senior author Masaharu Kobayashi.

This work is an important step towards the “edge AI”, in which many small AI-enabled appliances communicate as part of an integrated “smart-home.”

## Reference

“A Monolithic 3D Integration of RRAM Array with Oxide Semiconductor FET for In-memory Computing in Quantized Neural Network AI Applications”  
*VLSI Technology Symposium (2020)*



# “WOOD” you like to recycle concrete?

Researchers at UTokyo-IIS, have developed a new procedure for recycling concrete with the addition of discarded wood. They found that the correct proportion of inputs can yield a new building material with a bending strength superior to that of the original concrete. This research may help drastically reduce construction costs, as well as slash carbon emissions.



The recycled concrete with a ginkgo leaf, which is the symbol of UTokyo.

Concrete has long been the material of choice for construction our modern world, used in structures such as skyscrapers, bridges, and houses—to name just a few. However, as countries work to constrain their greenhouse

emissions, concrete production has fallen under increased scrutiny. Concrete consists of two parts, aggregate—which is usually made of gravel and crushed stone—and cement. It’s the production of cement that is blamed for a large amount of the carbon dioxide humans release into the atmosphere.

“Just reusing the aggregate from old concrete is unsustainable, because it is the production of new cement that is driving climate change emissions,” explains first author Li Liang. Therefore, a new, environmentally friendly approach is needed to help promote the circular economy of concrete. The researchers optimized their new method by adjusting the mixture proportion, pressure, temperature, pressing duration, and water content. Finding the right proportion of concrete and recycled wood was critical to obtaining concrete with the most strength. Wood gets its rigidity from lignin, which are highly crosslinked organic polymers. In this case, lignin fills the gaps in the concrete and functions as an adhesive when mixed with waste concrete powder and heated. The strength was also improved by higher temperatures and pressures during pressing.

“Most of the recycled products we made

exhibited better bending strength than that of ordinary concrete,” says senior author Associate Professor Yuya Sakai. “These findings can promote a move toward a greener, more economical construction industry that not only reduces the stores of waste concrete and wood, but also helps address the issue of climate change.”



The recycled concrete with wood and concrete wastes. More concrete was used towards right.

The recycled concrete is even likely to be biodegradable, because the concrete waste is attached to the wood component. The method could also be extended to recycle other types of discarded plant matter, instead of wood, or even brand-new concrete made from plants, sand, and gravel.



Associate Professor Yuya Sakai

Reference

“Experimental Study of the Bending Strength of Recycled Concrete and Wooden Waste by Heating Compaction”  
*The Sixth International Conference on Construction Materials (ConMat'20)*



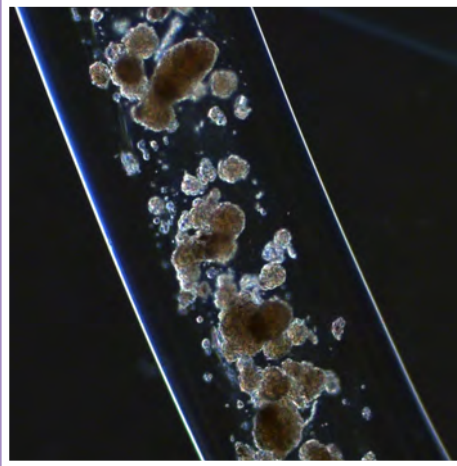

## Diabetic Mice Improve With Retrievable Millimeter-thick Cell-laden Hydrogel Fiber

A research team led by Shoji Takeuchi developed a novel fiber-shaped hydrogel transplant for the treatment of type 1 diabetes mellitus. They showed that pancreatic cells encapsulated in 1.0-mm-thick hydrogel fibers normalized blood glucose levels in diabetic mice while being protected from foreign body reactions. These findings help facilitate cell-based therapies for type 1 diabetes mellitus.

*Biomaterials* (2020), DOI: 10.1016/j.biomaterials.2020.120162

**Further information** <https://www.iis.u-tokyo.ac.jp/en/news/3313/>

## Artificial pieces of brain use light to communicate with real neurons

Researchers at UTokyo-IIS, University of Bordeaux and at Ikerbasque have created a way for artificial neuronal networks to communicate with biological neuronal networks. The new system converts artificial electrical spiking signals to a visual pattern that is then used to entrain the real neurons via optogenetic stimulation of the network. This advance will be important for future neuroprosthetic devices that replace damaged neurons with artificial neuronal circuitry.

*Scientific Reports*(2020), DOI: 10.1038/s41598-020-63934-4

**Further information** <https://www.iis.u-tokyo.ac.jp/en/news/3300/>

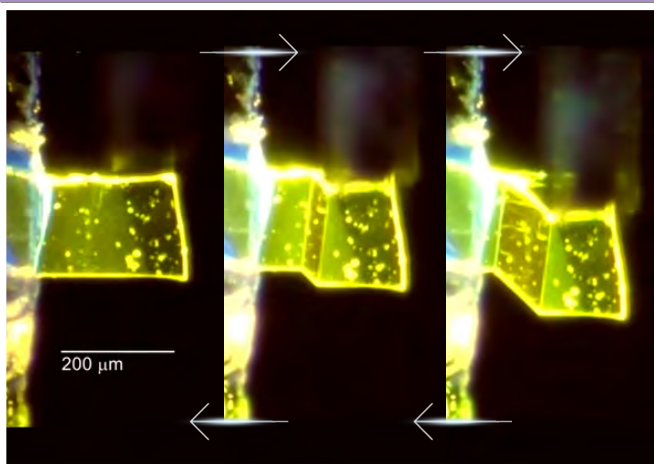
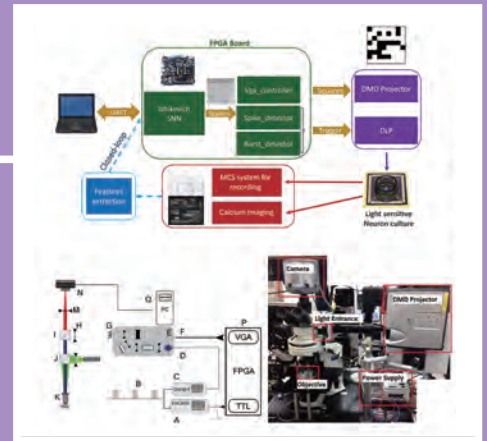

## Red Light for Stress

A research team led by Toshiki Mutai have created a biphasic luminescent material that changes color when exposed to mechanical stress. This work has many applications in the field of smart materials, which includes sensors for monitoring the strain on objects.

*Nature Communications*(2020), DOI: 10.1038/s41467-020-15663-5

**Further information** <https://www.iis.u-tokyo.ac.jp/en/news/3285/>

## Slow-motion interplate slip detected in the Nankai Trough near Japan

Japanese researchers used a Global Navigation Satellite System–Acoustic ranging combination technique to detect signals due to slow slip events in the Nankai Trough with seafloor deformations of 5 cm or more and durations on the order of one year. These events generally occurred on the shallow sides of regions with strong interplate coupling and represent variations in interplate friction conditions, which may help simulate the occurrence of megathrust earthquakes originating from this subduction zone and contribute earthquake disaster prevention.

*Science Advances*(2020), DOI: 10.1126/sciadv.aay5786

**Further information** <https://www.iis.u-tokyo.ac.jp/en/news/3223/>







# UTokyo - IIS

Since its establishment in 1949, the Institute of Industrial Science at the University of Tokyo (UTokyo-IIS) is one of the largest university research institutions in Japan and its history reaches 70 years.

Our multidisciplinary research covers nearly all fields of engineering, and our professors, associate professors, and lecturers each lead dedicated laboratories, about 120 in total. More than 1,000 personnel, comprising approximately 300 faculty members including staffs and 750 graduate students, participate in educational and research activities that are responsible for producing excellent research outcomes and fostering outstanding talent. All our laboratories belong to one of five core research departments and some straddle multiple departments, providing the warp and weft for nine research centers, three collaborative research centers, and two international collaborative research centers. As well as promoting original research in each specialist field, we as an institution encourage cross-disciplinary and international activities. Last year saw the functions of the Chiba Experiment Station transferred from its original home in Nishi-Chiba to our Kashiwa campus, and the launch of the new Design-Led X Platform.

Since the foundation of the Institute, we have been acutely aware that the significance of academic research into engineering lies in its real-world implementation, and together with the seeding of new academic disciplines through enhanced specialization and cross-disciplinary collaboration, we have developed and deployed new technologies that contribute to solving problems in the real world. We have also made it our mission to nurture talented people to shoulder the responsibility of technological development and dissemination, especially in the industrial world. Such a philosophy and sense of mission has been programmed into our DNA since the foundation of the Institute, and we have taken a hands-on approach to address engineering challenges as a pioneer of advocacy for collaboration between industry



**Professor Toshiharu Kishi, Director General**

and academia. We also take pride in the fact that our achievements and proactive stance are widely recognized together with the name *Seiken*.

Society is facing diverse problems today, and expectations are growing for the role that engineering plays in solving these problems. At the same time, the challenge for conventional engineering is that it is unable to make widely-accepted and compelling products with an approach that focuses only on technological development. For such situations that are difficult to address with engineering alone, we are seeking to build a new *Seiken* style—one that contributes to the creation of compelling value through innovation, founded on the pursuit of academic truth as a university research institute, and adding a multidisciplinary approach integrating humanities and sciences that incorporates exit strategies for real-world implementation, to the style that it is long known for: barrier-free, cross-disciplinary, practical industry-academia collaboration, and ambitious international collaboration.

Even though it is the largest of its kind in Japan, *Seiken* is perfectly sized to maintain a strong sense of organizational unity, and through our agility and collective strength as a world-class research institute in the field of engineering, we hope to continue helping to make everyone's dreams come true.

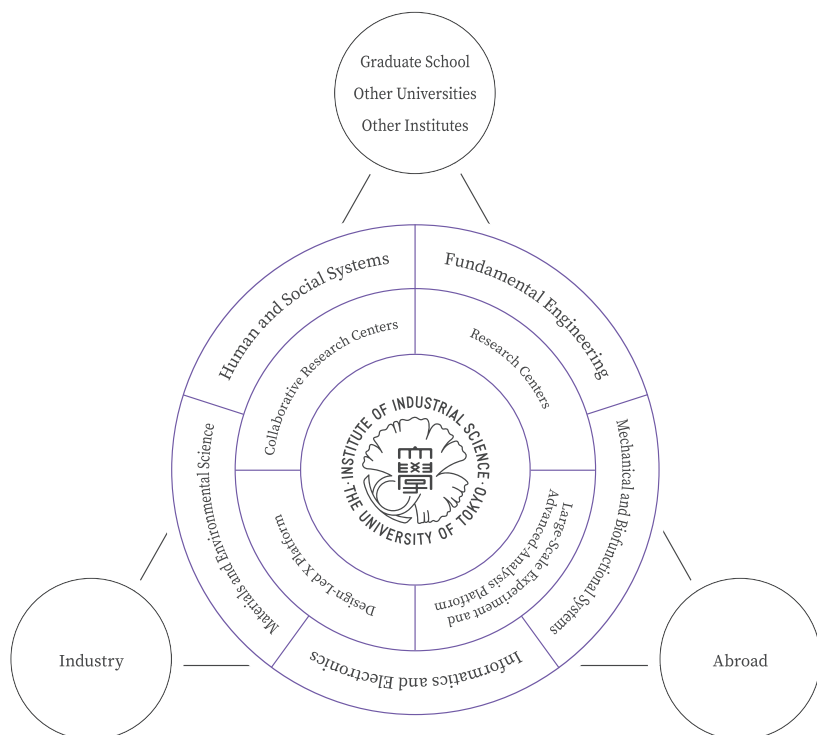

Five Research Departments and Research Centers

**Institute of Industrial Science,  
The University of Tokyo  
(UTokyo-IIS)**

<https://www.iis.u-tokyo.ac.jp/>

**Komaba Research Campus  
(Komaba II Campus)**

4-6-1 Komaba Meguro-ku, TOKYO  
153-8505, JAPAN  
E-mail: [koho@iis.u-tokyo.ac.jp](mailto:koho@iis.u-tokyo.ac.jp)

**Large-Scale Experiment  
and Advanced-Analysis Platform (LEAP)**

5-1-5 Kashiwanoha Kashiwa-shi, CHIBA  
277-8574, JAPAN  
E-mail: [chibajim@iis.u-tokyo.ac.jp](mailto:chibajim@iis.u-tokyo.ac.jp)

**Publications**

<https://issuu.com/utokyo-iis>



**UTokyo-IIS Bulletin**  
Institute of Industrial Science,  
The University of Tokyo

pro@iis.u-tokyo.ac.jp  
<https://www.iis.u-tokyo.ac.jp/>